

# Regulator Pressure-compensated Valves (Fixed Orifice)

BBLF08-00/X.Y.Z

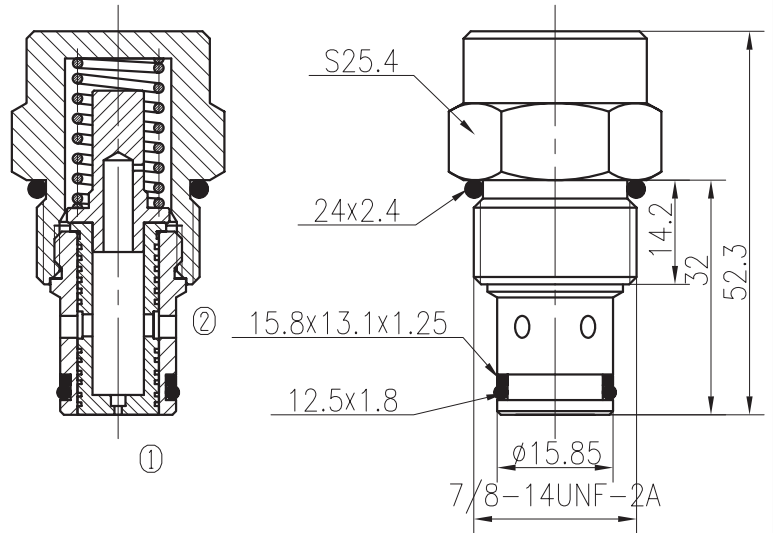
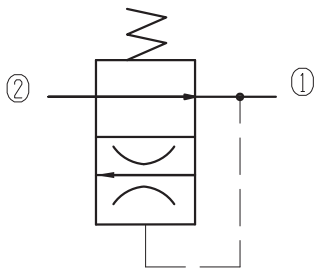

## Specifications:

Max working Pressure :	240bar
Flow Max :	20L/min
Filtration Of Oil :	25µm or better
Temperature :	-30~+100°C (Standard Buna Seals)
Cavity :	T5-1
Installation torque :	33.9~36.7Nm

The valve maintains a constant flow rate out of ② regardless of load pressure changes in port ①. That is to say, when flow from ① to ② through the control office is compensated and reverse flow from ② to ① returns through the control office and is non-compensated.

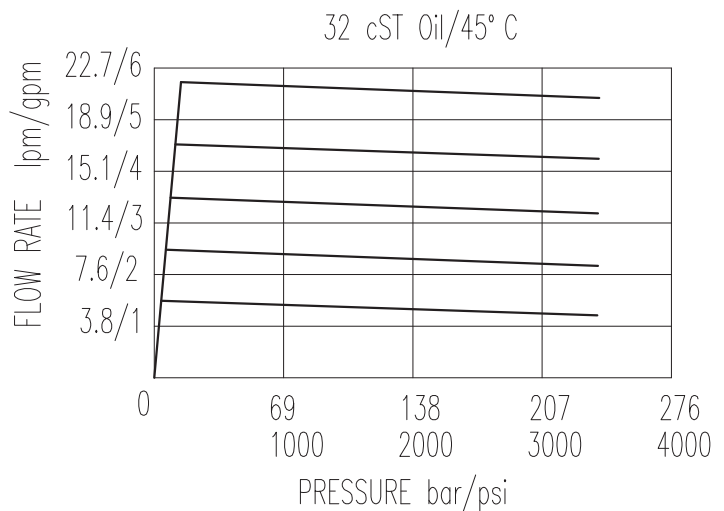

X	PORTING	Y	SEALS
0	Cartridge Only	N	Buna
4G	G1/4	V	Fluor.
8G	G3/8		
4T	SAE4		
6T	SAE6		

Z	SPRINGS AND OFFICE	
	Flow Maintenance L/min	Flow Settings L/min
05	0.4~2.0	±20%
10	2.1~5.8	±15%
15	6.0~20.0	±10%