

BFPF20-02/X.Y.Z

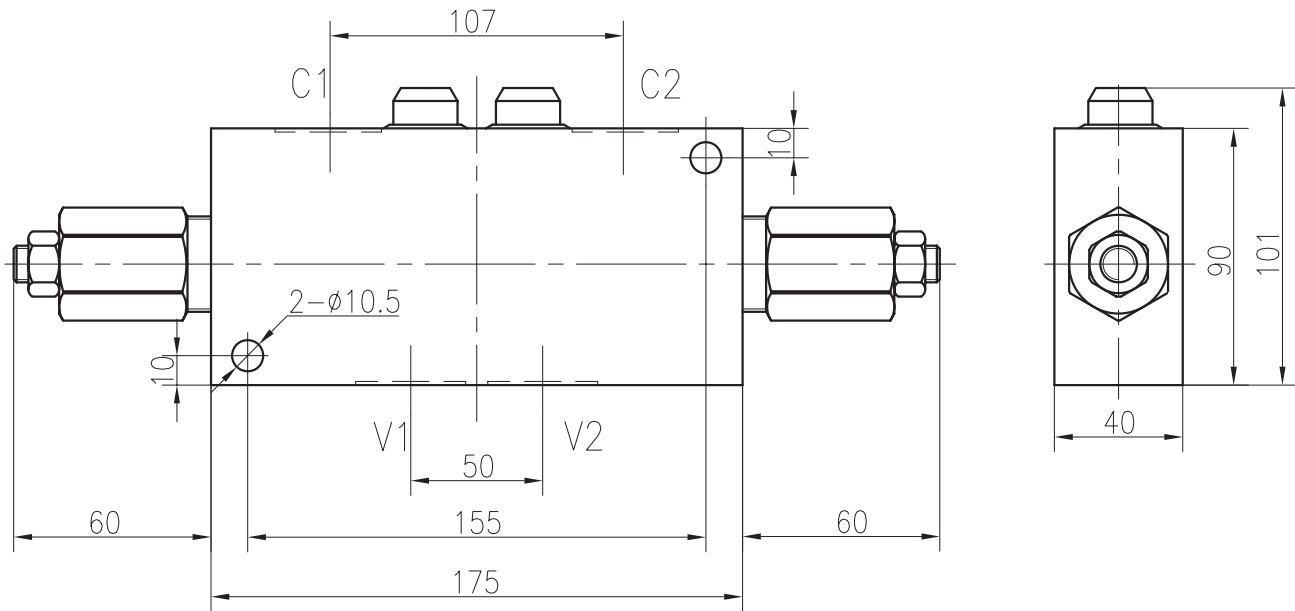

Specifications:

| | |
|------------------------|------------------------------------|
| Max.Working Pressure : | 240/350bar |
| Flow Max : | 140L/min |
| Internal Leakage : | <0.4ml/min |
| Filtration Of Oil : | 25µm or better |
| Temperature : | -30~+100℃ (Standard Buna Seals) |
| Pilot Ratio : | 3.0:1 |

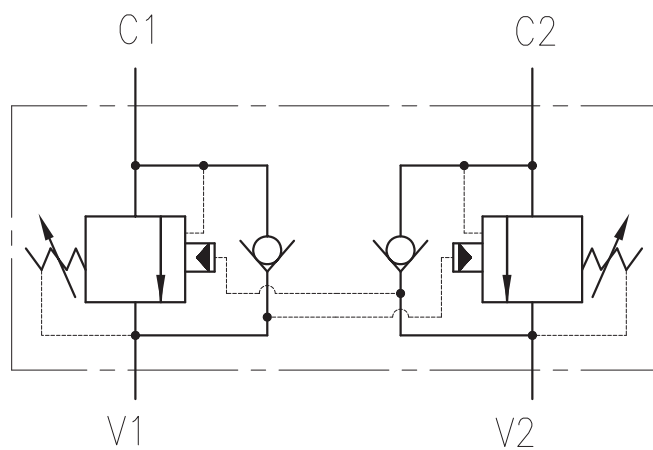

| X | PORTING MATERIAL | | Y | SEALS |
|-----|------------------|------|---|--------|
| 3GA | Lc4 | G1/2 | N | Buna |
| 8GA | | G3/4 | V | Fluor. |
| 3GS | Steel 45 | G1/2 | | |
| 8GS | | G3/4 | | |

| Z | SPRINGS | | | |
|----|------------------|--------------------------|----------------------|---------------------|
| | Press. range bar | Press. increase bar/turn | Standand setting bar | Cracking press. bar |
| 05 | 60~240 | | 207 | 170 |
| 10 | 60~350 | | 210 | 170 |