

BFPF20-01/X.Y.Z

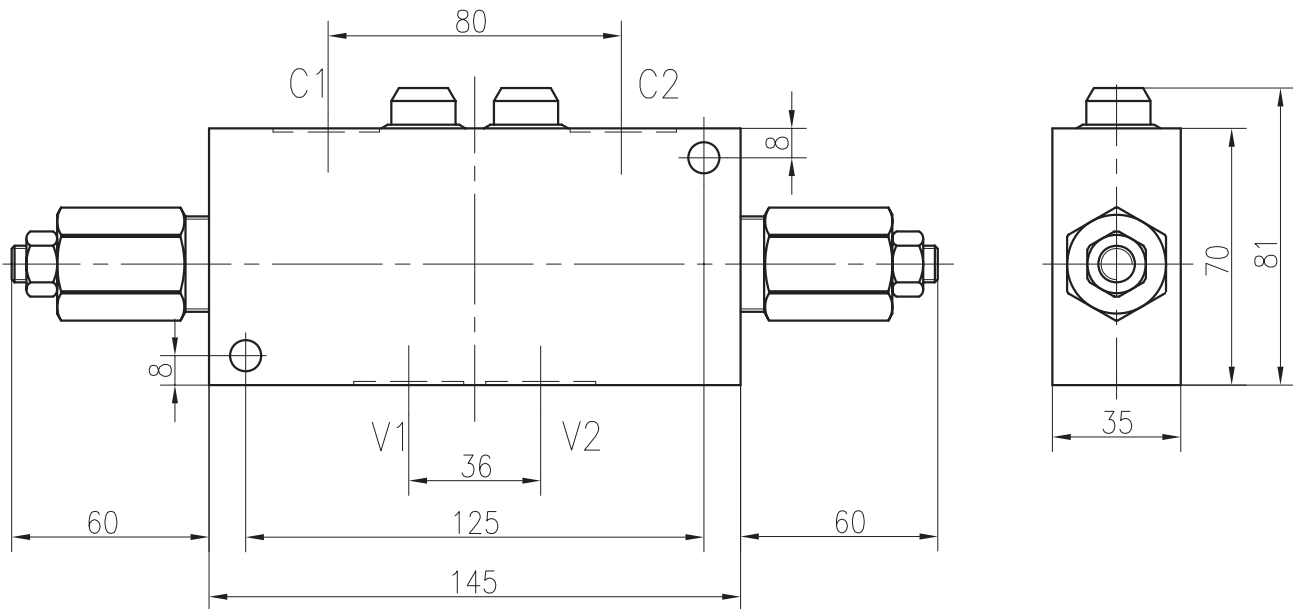

Specifications:

Max.Working Pressure :	240/350bar
Flow Max):	120L/min
Internal Leakage :	<0.4ml/min
Filtration Of Oil :	25μm or better
Temperature :	-30~+100℃ (Standard Buna Seals)
Pilot Ratio :	8.15:1

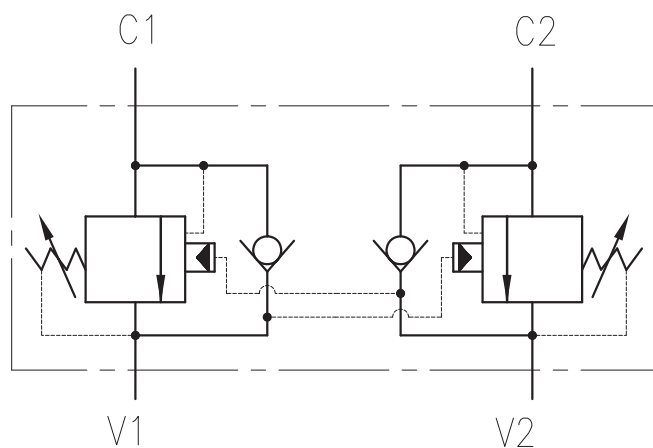

X	PORTING MATERIAL		Y	SEALS)	Z	SPRINGS			
						Press. range bar	Press. increase bar/turn	Standand setting bar	Cracking press. bar
3GA	Lc4	G1/2	N	Buna)	05	60~207		207	170
8GA		G3/4	V	Fluor.)	10	60~350		210	170
3GS	Steel 45	G1/2							
8GS		G3/4							