

Check Valves (Poppet-type)

BDF20-03/X.Y.Z

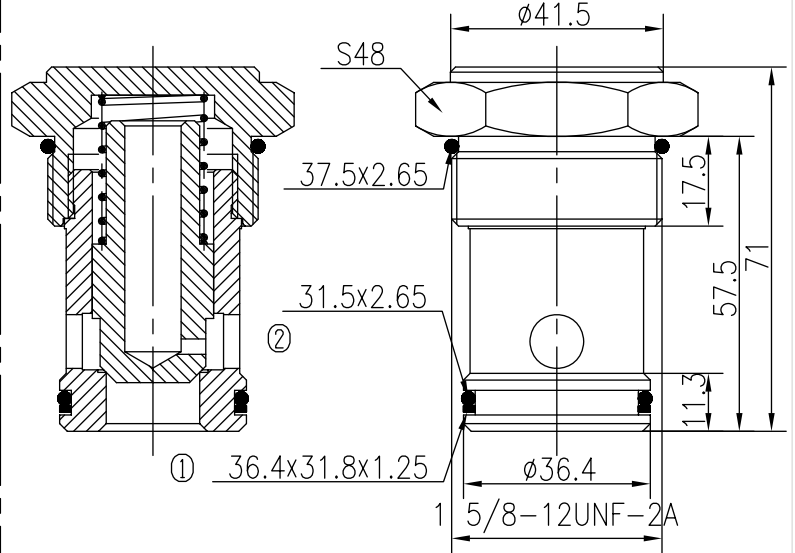
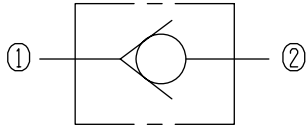

Specifications:

Max working Pressure :	240bar
Flow Max :	400L/min
Internal Leakage :	$\leq 0.3\text{ml/min}$ at 210bar
Filtration Of Oil :	25 μm or better
Temperature :	-30~+100 $^{\circ}\text{C}$ (Standard Buna Seals)
Cavity :	T8-1
Installation torque :	88.4~102Nm
Standard Block Model	T8-11*/13*/14*/16*

The valve allows flow from ① to ② with very low pressure drop, while blocks flow from ② to ①.

The valve blocks flow from ① to ② until sufficient pressure is applied at ②.

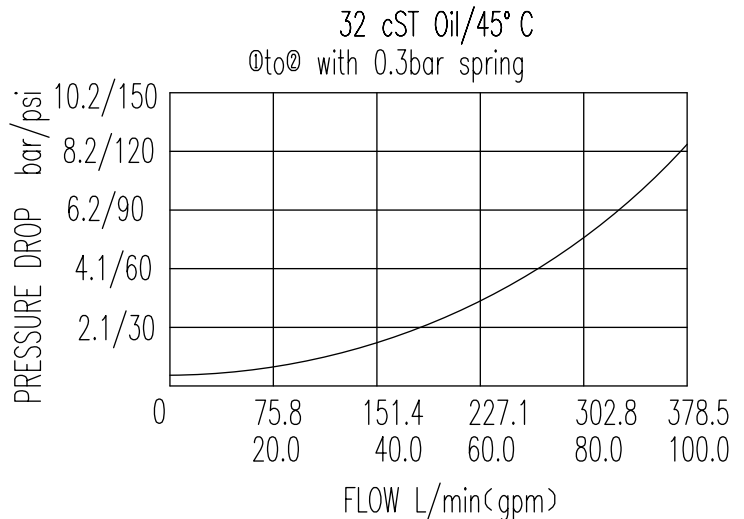

X	PORTING	Y	SEALS
0	Cartridge Only	N	Buna
20T	SAE20	V	Fluor

Z	SPRINGS	
	Cracking Pressure bar	Cracking Pressure bar
05	0.3	
10	1	
15	2	
20	4	