

Check Valves (Poppet-type)

BDF20-00/X.Y.Z

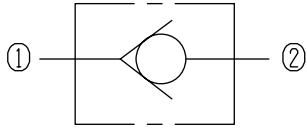

Specifications:

Max working Pressure :	240bar
Flow Max :	350L/min
Internal Leakage :	<0.3ml/min at 210bar
Filtration Of Oil :	25µm or better
Temperature :	-30~+100°C (Standard Buna Seals)
Cavity :	T8-S1
Installation torque :	88.4~102Nm

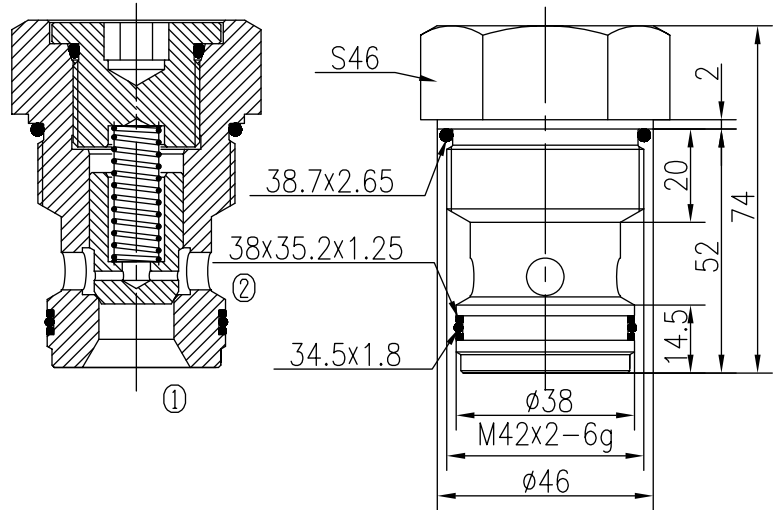

The valve allows flow from ① to ② with very low pressure drop, while blocks flow from ② to ①.

The valve blocks flow from ① to ② until sufficient pressure is applied at ②.

32 cST Oil/45° C

①to②

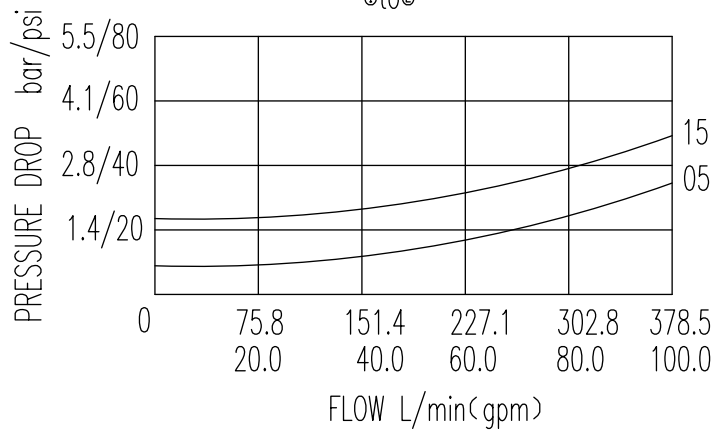

X	PORTING	Y	SEALS
0	Cartridge Only	N	Buna
		V	Fluor

Z	SPRINGS	
	Cracking Pressure bar	Cracking Pressure bar
05	0.5	
10	1	
15	1.6	
20	2	