

Three Way Two Position (Spool-type)

BST10-230

Description of the process

When de-energized, the valve allows flow from ② to ③, while blocking flow at ①;

When energized, the valve allows flow from ① to ②, while blocking flow at ③.

P--- (PRESSURE PORT)

A--- (WORKING PORT)

T--- (TANK PORT)

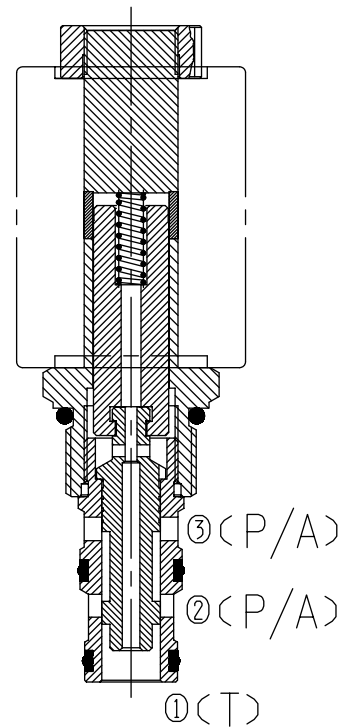

Specifications:	210bar
Max. Working Pressure	See Performance
Flow Max.	<80ml/min at 210bar
Operating Volt	12VDC, 24VDC, 110VAC, 220VAC
Min Voltage Requires	85% of normal voltage
Filtration Of Oil	20μm or better
Type of Standard Cavity	T5-2
Temperature	-30~+100°C Standard Buna Seals
Standard Block Model	T5-21*/23*/24*/26*

Symbol:

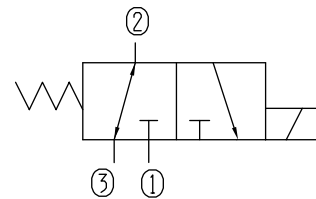

Characteristic: 32 cST Oil/40°C

② — ③ — (d)
② — ① — (e)

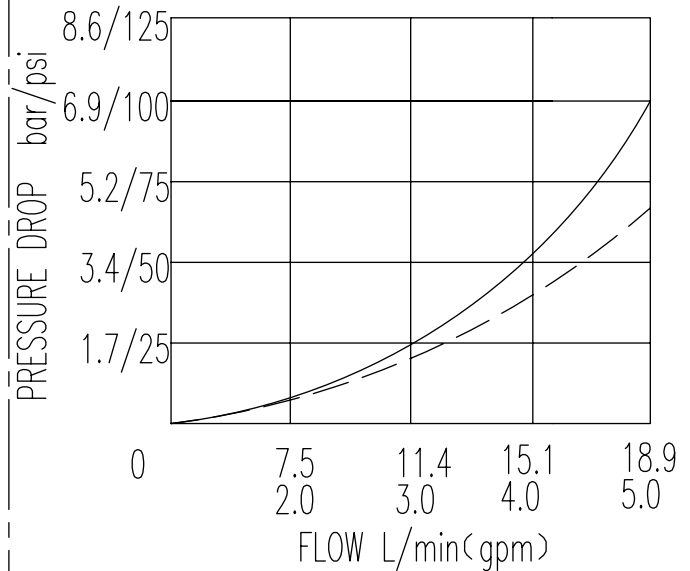

Three Way Two Position (Spool-type)

BST10-230

Profile dimensions

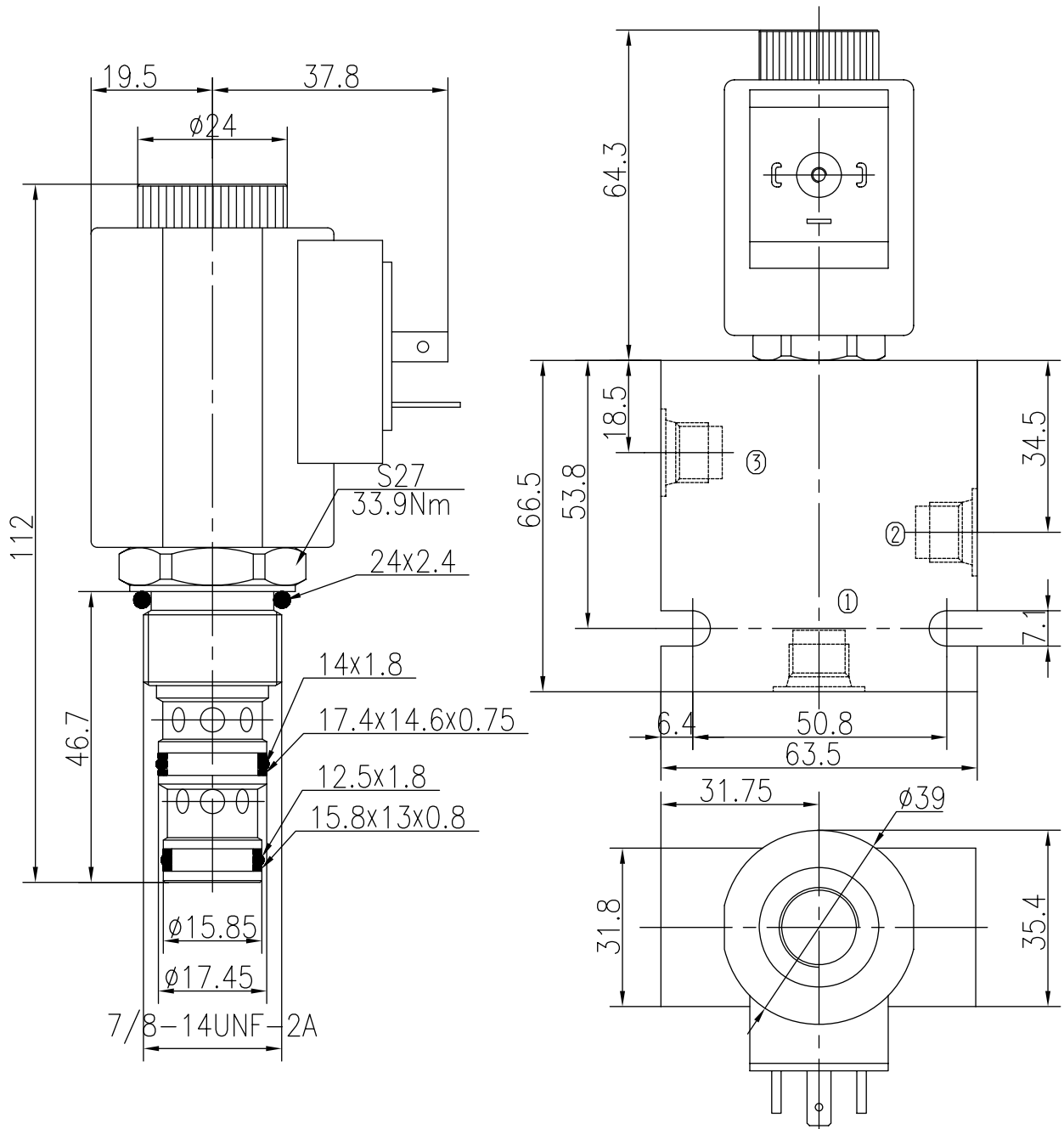

TO ORDER

BST10-230

Solenoid Valve
Function

Body Porting

Omit for Cartridge only

G1/4 4G
G3/8 8G
SAE4 4T
SAE6 6T

Seals

Buna(Std.) N
Fluorocarbon V

Voltage

12 12VDC
24 24VDC
110 110VAC
220 220VAC

Connection

DL Double Leads
DH Electrical Outlet